

WARRANTY

For 12 months (1 year) from the date of purchase, Lotus will repair or replace the Green Genie, free of charge, if defective in material or workmanship.

LIMITATION OF WARRANTY

LOTUS WILL NOT BE LIABLE FOR NORMAL "WEAR AND TEAR" ITEMS AS INDICATED IN THIS INSTRUCTION MANUAL OR ACCIDENTS, MISUSE, NEGLIGENCE OR USE WITH ANY LIQUIDS OTHER THAN COLD WATER.

NO LIABILITY IS ASSUMED WITH REGARD TO LOSS OR DAMAGE TO LIVESTOCK OR PROPERTY, IRRESPECTIVE OF THE CAUSE THEREOF. THIS WARRANTY DOES NOT AFFECT YOUR STATUTORY RIGHTS.

FAILURE CAUSED BY MISUSE IS NOT COVERED BY THIS WARRANTY.

HOW TO CLAIM

DO NOT return the Green Genie to the retailer. Either contact us by telephone, email, or send the unit, securely packed with your name and address to the address below. Enclose a brief note advising the nature of the fault. If repair is claimed under warranty, you must include a copy of your proof of purchase.

GREEN GENIE

COMBINED ULTRA VIOLET & POND FILTRATION SYSTEM

INSTALLATION AND MAINTENANCE INSTRUCTIONS

2000	12000
3000	24000
6000	48000



- Safety Instructions
- Installation
- Electrical
- Maintenance
- Spare Parts
- Warranty



Lotus Water Garden Products Ltd

Web: www.lotuswatergardens.com



Lotus Water Garden Products



www.lotuswatergardens.com

Safety/Installation/Electrical Instructions for all Models

WHY FILTER?

Pond pollutants are introduced via an accumulation of solids settling at the bottom. These can be categorised into two groups. 1. Fish waste products - faeces, ammonia, dissolved carbon dioxide, etc. 2. Decaying vegetation and uneaten fish food.

The solids quickly dissolve into the pond producing harmful bi-products, which are hazardous to fish health and may cause the water to become cloudy. Sunlight encourages algae, which makes the pond water green. The Green Genie Biological Filter and Ultra Violet Steriliser is designed to provide clean, clear water. The Biological effect ensures that the pond water is kept free of pollutants that can kill fish and plant life. The UV kills algae and harmful bacteria thereby making the pond water clear.

MECHANICAL FILTRATION

Mechanical filtration simply means the removal of the solids and prevention of their return to the pond. This is achieved by passing the water over layers, or layer of foam in the bio-filter. Coarse foam uppermost (all models), fine foam to bottom (models 24000 and 48000 only). Always place dimple side up.

BIOLOGICAL PURIFICATION

This is achieved by colonising the plastic filter medium with 'friendly' bacteria and micro-organisms which, when mature, digest pollutants thus neutralising harmful ammonia and nitrates.

UV STERILISATION

This occurs when the UV light penetrates the water as the water passes through the water chamber. It kills the algae and harmful bacteria thereby making the pond water clear.

INSTALLATION - THIS APPLIANCE IS NOT SUBMERSIBLE

Connect a hose from the pump to the multi hosetail fitting on the top. The outlet water should be routed back to the pond. On initial set up allow the unit to operate for a week before switching on the electricity supply to the ultraviolet steriliser. This allows the filter to be colonised by friendly bacteria.

Always run 24 hours a day for maximum efficiency.

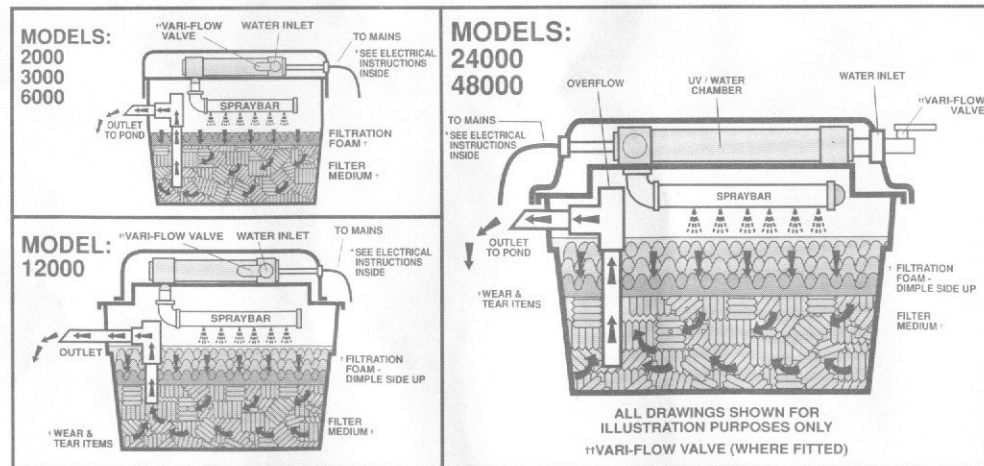

ELECTRICAL CONNECTION

- UV Sterilisers are designed for permanent installation to the mains supply via a switched fused connection, using a 3 amp fuse.
 - A 30 mA (or less) Residual Current Device (RCD) (standard circuit breaker) **MUST BE** fitted to the mains supply.
 - This appliance **MUST BE** earthed.
 - Always unplug or disconnect the UV Steriliser from the electricity supply before putting your hands (or any part of your body) in the water. The wires in the mains lead are coloured in accordance with the following code: **BROWN - LIVE BLUE - NEUTRAL GREEN/YELLOW - EARTH**
- IF IN DOUBT CONSULT A QUALIFIED ELECTRICIAN**

Maintenance for all Models

CLEANING

The efficiency of the filter depends on the foam and the Flocor being colonised. The foams should not be cleaned unless water is passing down the overflow pipe. Usually only the top layer needs to be cleaned. Remove and shake clean whilst hosing with clean water. The Flocor filter medium should never be cleaned; however it can be removed to facilitate the removal of silt from the bottom of the filterbox. Please note that the foam should be replaced every year.

ULTRA VIOLET STERILISER MAINTENANCE

When installing your Green Genie, if you need to use an extension lead use only the correct PCP cable and waterproof (IP68) or weatherproof (IP67) cable connectors. Remember that pets and wildlife often damage cable, so it is advisable to run your cable through a length of hose and protect the connectors with an arrangement of rocks or bricks.

No routine maintenance is required. Routine replacement of the lamp is recommended no later than 8000 hours, or 12 months, whichever is sooner.

REPLACING BULB & QUARTZ SLEEVE

(all 'wear and tear' items)

Models 2000, 3000 & 6000: (SHOWN ABOVE)

- 1) Isolate Steriliser from mains supply and switch off Genie.
- 2) Remove the two lid-retaining (self-tapping) screws.
- 3) Remove Genie lid.
- 4) Undo the hosetail by turning anti-clockwise.
- 5) Remove spray bar by unwinding anti-clockwise.
- 6) Separate the base from the lid. Pull the cable through as you do so (remove hosetail on 12000 model).
- 7) Disconnect the lamp holders and pull out the bulb from housing.

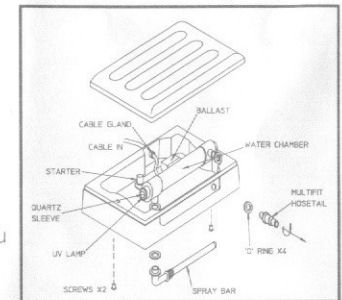

Models: 2000, 3000 & 6000

- 8) Unscrew the two compression fittings from the ends of the water chamber and remove 'O' rings.
- 9) Slide out quartz sleeve; handle with care as it is brittle. Clean the quartz sleeve with domestic acid or ammonia-based cleaning solution rinsing thoroughly afterwards. If quartz sleeve is excessively scratched, then replace.
- 10) Refit the quartz sleeve with the 'O' rings and tighten up the compression fittings by hand.
- 11) Replace the lamp and refit the lamp holders.

REPLACING UV BULB & QUARTZ SLEEVE - Models: 12000, 24000 & 48000

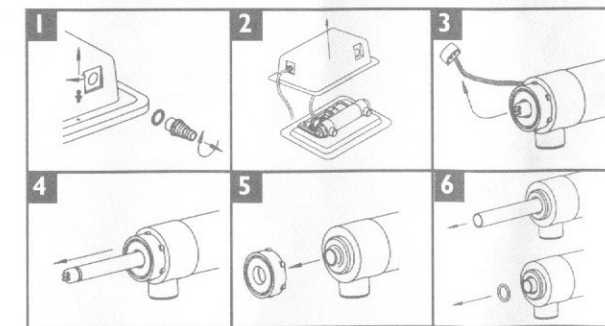

1. Remove hosetail & sail.
2. Remove push clips and lid.
3. Remove lamp holders from UV bulb.
4. Remove UV bulb.
5. Unscrew endcaps at each end of UV chamber.
6. Remove 'O' rings' and remove quartz sleeve. To re-assemble reverse the above procedure.

If you are unsure whether or not the unit is working, place a piece of white paper or card at the end close to the hosetail. If a blue-violet coloured light is reflected on to the paper, then the lamp is working correctly. The replacement should be a Germicidal Ultra Violet Lamp. If you wish us to undertake the refitting, please do not hesitate to call us on our Customer Service number below.

Remember the lamp emits harmful UV-C radiation so the burning lamp should never be observed.